

EG4 18kPV Monitoring Adapter | WLAN-Ethernet

Quick Setup Guide

Note: A customer code is required to register a Monitor Account. The customer code must be provided by the installation personnel or a distributor. The end user needs to apply to your installation personnel to register a Monitor account, or you can register

Step 1. Create an end-user account by:

- registering at <https://monitor.eg4electronics.com/>. **OR**
- downloading the 'EG4 Monitor' app. The 'EG4 Monitor' app is available via Google play or the Apple APP store.

APP Name: EG4 Monitor



Scan the QR code which will take you to the EG4 Electronics downloads page. Look for the 18KPV-12LV inverter downloads, then tap on the appropriate app link.

NOTE: To create a distributor or installer account, please contact support@eg4electronics.com for assistance.

Using Phone to Register:

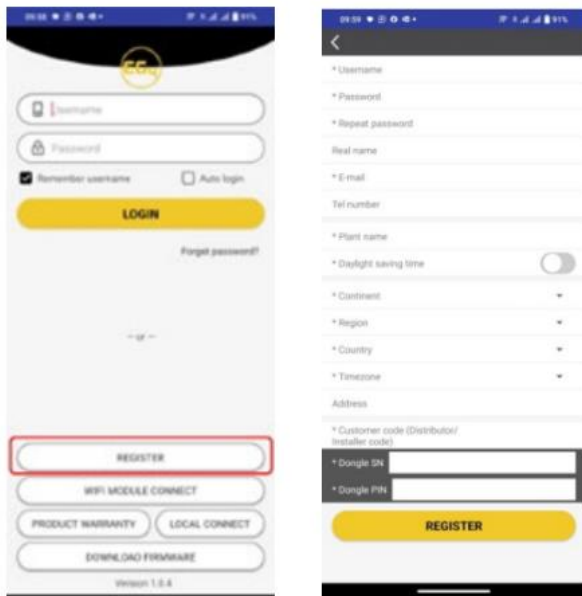

Using Web to Register:

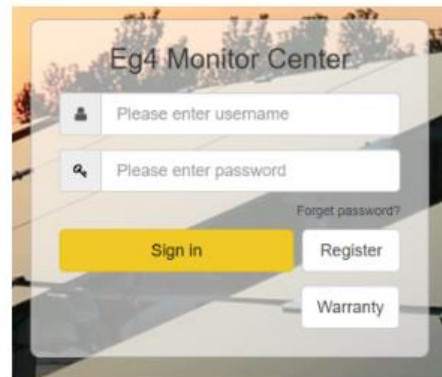

Step 2. Install the Datalogger:

- Power down the inverter, following the proper shutdown procedures found in section 6.4 of the user manual which can be downloaded here: <https://eg4electronics.com/downloads/>
- Plug the datalogger into the inverter and affix with the four screws provided (see diagram to the right).

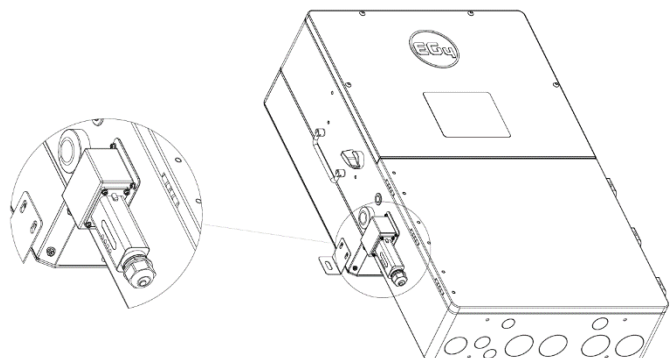

- c. Prepare a common ethernet cable (568B Configuration) and connect one end of the Ethernet cable to a port on your router and the other end to the WLAN Dongle (see figure below).

NOTE: It is recommended to use a shielded cable and the length should not exceed 65 ft. (20m).

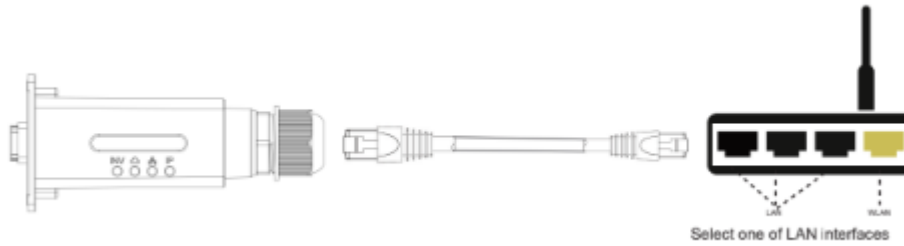

LED Indicator Descriptions:

LED	Name of LED	Description
1	INV LED	Communication between WLAN Dongle and Inverter
2	Cloud LED	Communication between WLAN Dongle and the internet
3	Network LED	Communication between WLAN Dongle and Router
4	IP LED	IP Address indicator light

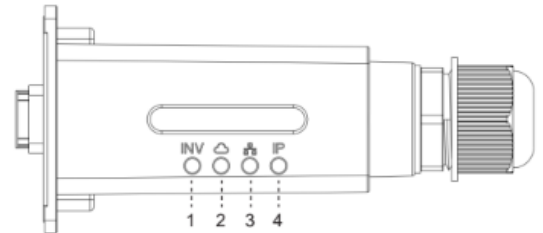

Troubleshooting Guide:

LED Status	Working Status
All LEDs are 'ON'	Communication Normal
INV LED flashing	Failure of communications between the WLAN Dongle and inverter
Cloud LED flashing	Failure of connection to internet
Network LED flashing	Failure of connection to router
IP LED flashing	Router has not enabled dynamic IP address allocation

Q&A :

Q: Why is the IP LED continuously flashing?

A: 1. The router's automatic IP allocation feature has not been enabled.

2. The Ethernet cable length exceeds the maximum communication distance of 65ft (20m) between the inverter and WLAN dongle.

3. A 568B configuration Ethernet cable has not been used.

Q: Why is the Network LED continuously flashing?

A: 1. The router is not connected to the internet.

2. The Ethernet cable length exceeds the maximum communication distance of 65ft (20m) between the inverter and WLAN dongle.

3. A 568B configuration Ethernet cable has not been used.

Q: Why is the Cloud LED continuously flashing?

A: Please check if the WLAN Dongle has been added to the power station.

Q: Why is the INV LED continuously flashing?

A: Please check the connection between the WLAN Dongle and the inverter, and ensure that the connectors are fully inserted.